



COMMUNITY REDEVELOPMENT AGENCY PROJECT PROGRESS REPORT
MAY 13, 2026
CRA MEETING

CRA Projects:

Project Name	Page/Slide No.
4642 Vincennes Boulevard Parking Lot.....	3
4813 Vincennes Street Parking Lot.....	5
Big John’s Request for Interest (RFI).....	7
Club Square Compactors and Enclosures.....	9
Cape Coral Parkway 6-Laning, Signal Retiming, and Parking	11
Country Club Blvd Median Landscaping.....	13
Palm Tree Blvd Median Landscaping Project.....	15
Cape Coral Pkwy Streetlight Retrofit.....	17
Bimini Basin Mooring Field.....	18
Founders Park - Captains Walk.....	20
Palm Tree Public Square	22
Bimini East.....	24

4642 Vincennes Boulevard Public Parking

Project Number: C193001007

Estimated Completion Date: Fall 2026

Scope of Work: 4642 Vincennes Blvd. (North of Cape Coral Parkway E) - Design and construct of a 40-space parking lot to include landscaping, curbing, paving, drainage inlets, lighting and EV infrastructure.

Approved Budget: \$659,591

Expenditures to Date: \$73,566.50

Completed Tasks:

March

The consultant has completed revisions addressing the latest review and meeting comments and is coordinating with SDP permit reviewers to schedule the final site plan approval meeting.

April

After SDP permit approval of 4642 Vincennes Blvd and 4813 Vincennes St parking lot - the intent is to package the projects together for solicitation of construction bids.



Project Lead: Allen Chenoweth, Sr. Project Manager/PW

4642 Vincennes Boulevard Public Parking

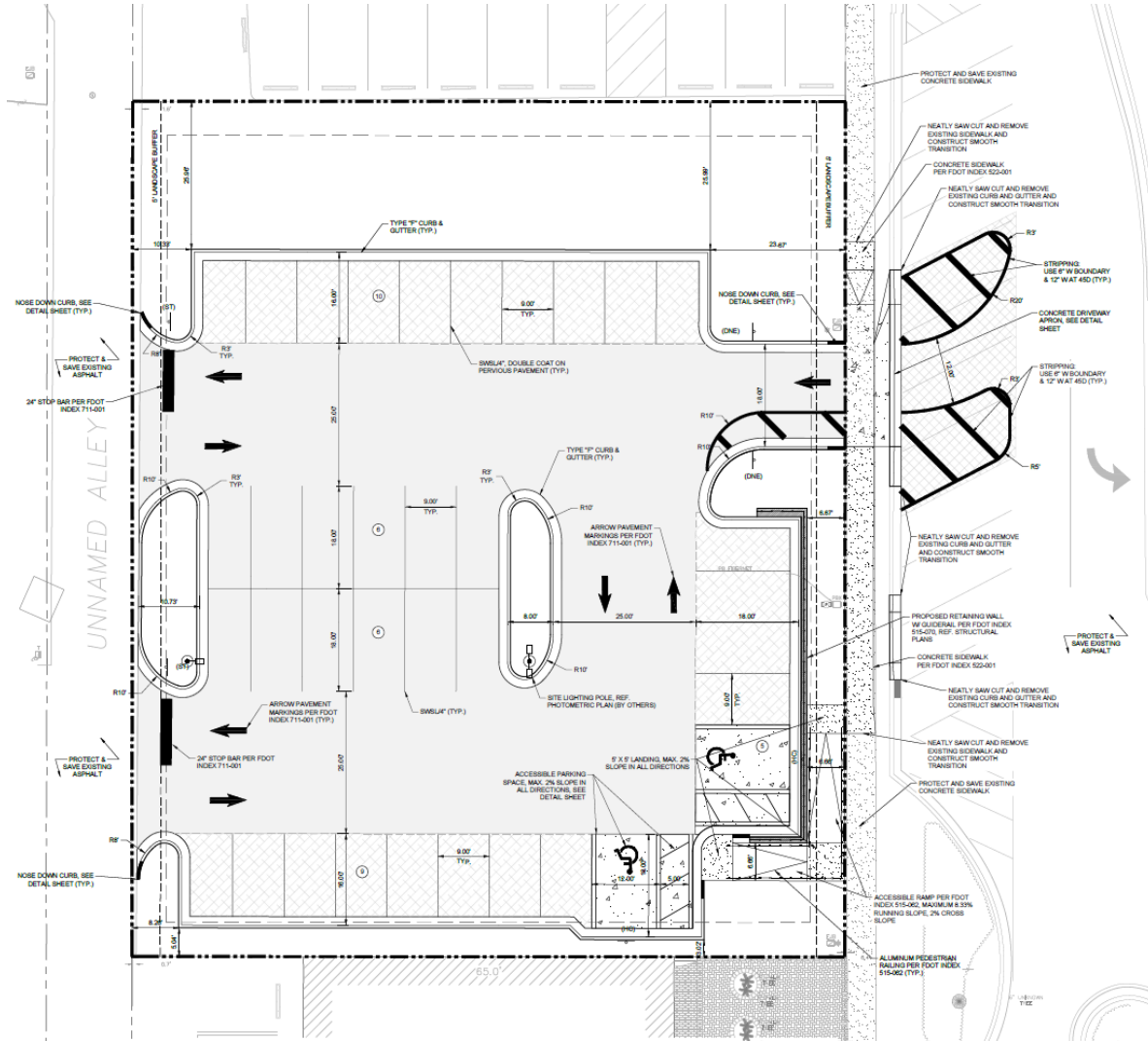

4813 Vincennes Street Public Parking

Project Number: C193001007

Estimated Completion Date: Fall 2026

Scope of Work: 4813 Vincennes St. (South of Cape Coral Parkway)

Design and construct of a 20-space parking lot to include landscaping, curbing, paving, drainage inlets, lighting and EV infrastructure.

Approved Budget: \$371,020

Expenditures to Date: \$57,387

Completed Tasks:

March

Revised SDP was submitted via email for a precheck. Subsequence meeting with Stormwater was held to discuss stormwater credits.

April

Design firm is working with SFWMD to utilize stormwater credits.



Project Lead: Zachary Gogel, Project Manager/CRA

4813 Vincennes Street Public Parking

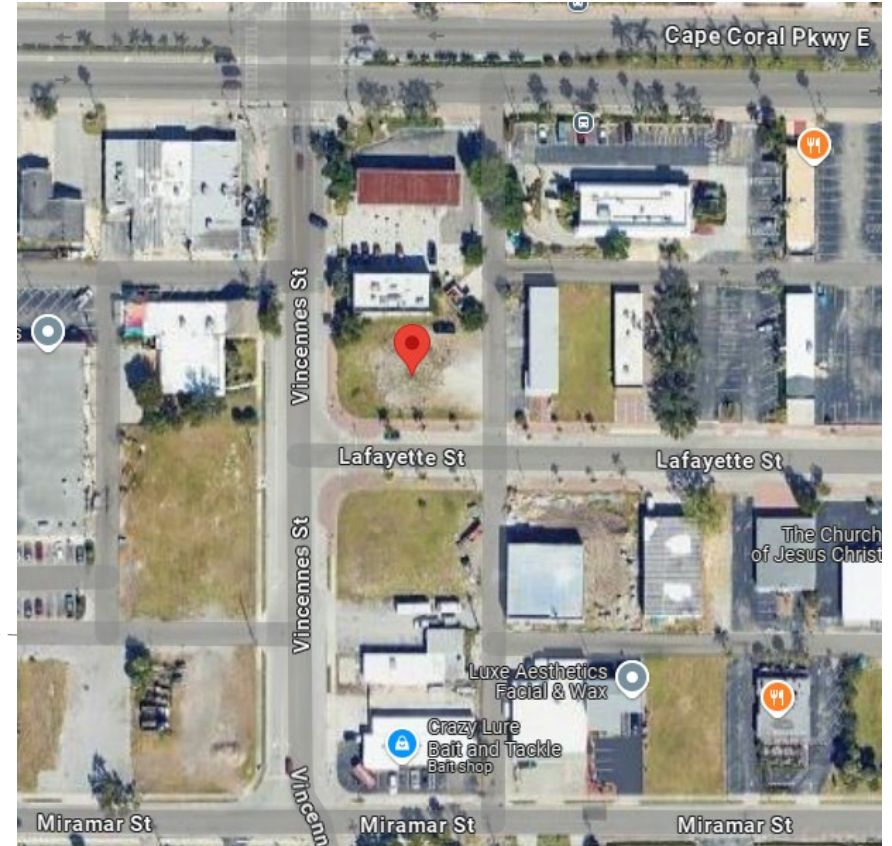
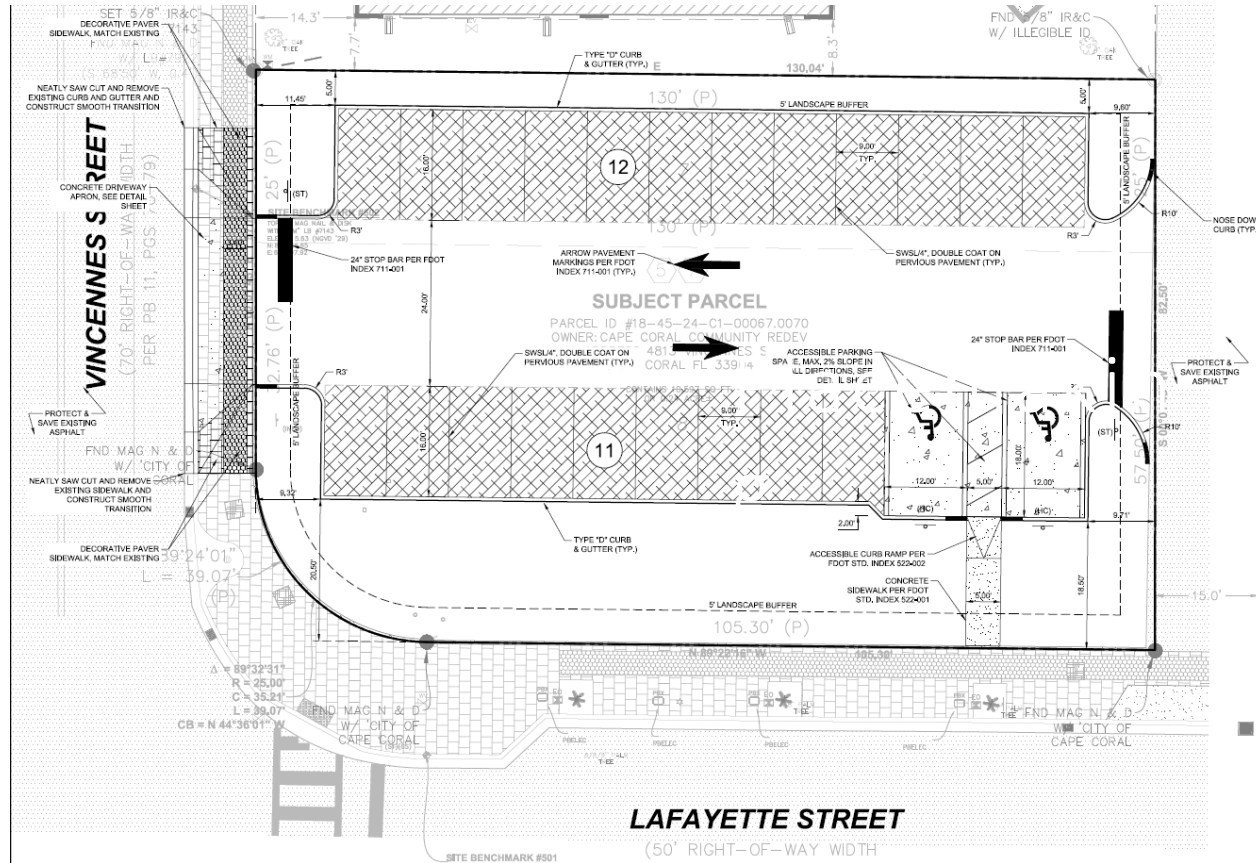

Big John's Request for Interest (RFI)

Scope: Request for Interest (RFI) for a mixed-use development on Big John's parking lot that incorporates the CRA's Redevelopment Plan. The project could double the existing public parking capacity and add trash compactors for businesses that currently use the parking lot dumpsters.

Completed Tasks:

April Adjustments made to RFI to reflect portion of adjacent property sale prior to sending out. RFI recently transmitted to Procurement.



Project Lead: Zachary Gogel, Project Manager/CRA

Club Square Compactors and Enclosures

Project Number: C193001015

Estimated Completion Date: Spring 2027

Scope of Work: Replace dumpsters with compactors to increase capacity and parking spaces. Improvements to dumpster enclosures including steel powder coated gates and concrete shiplap walls.

Approved Budget: \$370,000

Expenditures to Date: \$0

Completed Tasks:

March

Working with firm to create Staff Cost Proposal.

April

Firm working with sub-consultants to finalize Staff Cost Proposal.



Project Lead: Zachary Gogel, Project Manager/CRA

Club Square Compactors and Enclosures

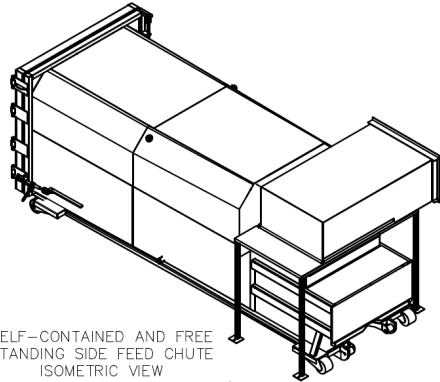

SELF-CONTAINED AND FREE
STANDING SIDE FEED CHUTE
ISOMETRIC VIEW
(WALL NOT SHOWN FOR CLARITY)

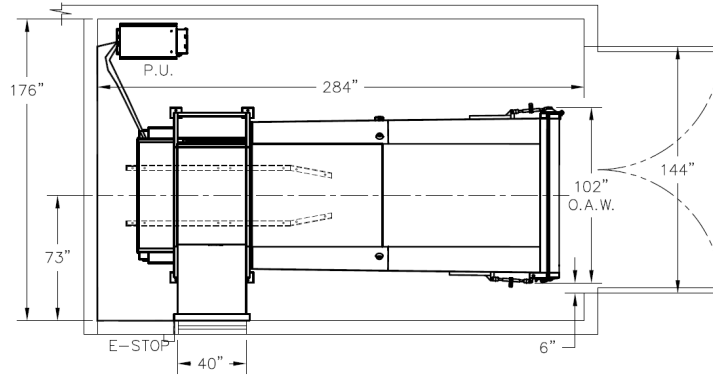

NOTE: PAD TO BE MINIMUM OF 6" THICK WITH STEEL REINFORCEMENT OF A MINIMUM #6 MESH WIRE AND CONCRETE WITH A 3,000# MIX SPECIFICATION.

NOTE: THIS IS A CONCEPTUAL DRAWING ONLY. FIELD CONDITIONS MAY REQUIRE AN ALTERNATIVE LOCATION AND/OR DESIGN.

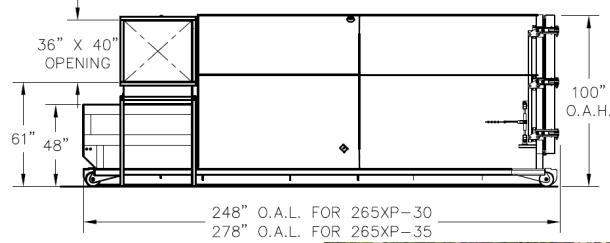
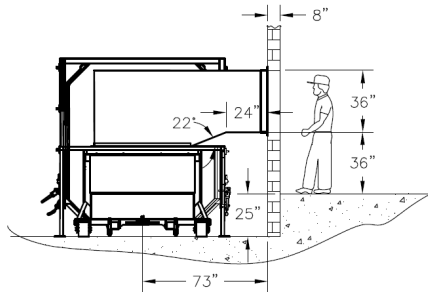

Cape Coral Parkway 6-Laning, Signal Retiming, and Parking

Construction Completion Date: November 30, 2026.

Scope of Work: : Cape Coral Parkway from Triton Ct E to near Del Prado Blvd. Construction will consist of making the area 3 lanes in each direction with resurfacing, restriping, one median removal, additional tree removal for safety clearances, and minor signal adjustments. Signal retiming will be done from Del Prado to Chiquita and 2 intersections on Del Prado once construction is completed.

Approved Budget: \$1,842,850**

Expenditures to Date: \$188,039

Completed Tasks:

March

Bids evaluated by staff.

April

Preconstruction meeting was held on 4/15/26 with Ajax Paving.

*Anticipated dates:

5/4/26 Notice to Proceed

5/11/26 Expected construction start

10/31/26 Substantial completion

**City funded project



Project Lead: Wendy Williams, PW, Principal Engineer PE

Cape Coral Parkway 6-Laning, Signal Retiming, and Parking Study

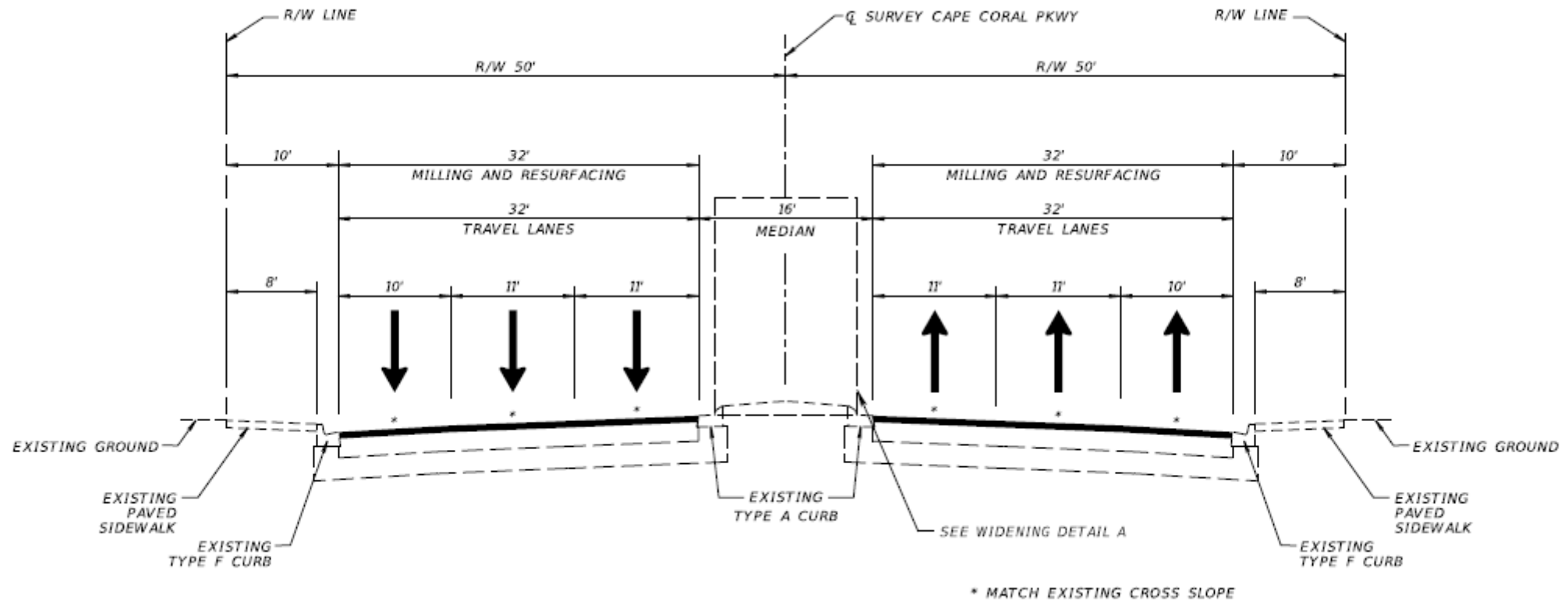

Country Club Blvd Median Landscaping

Project Number: C193001005

Estimated Completion Date: Summer 2026

Scope of Work: Country Club Blvd from Palm Tree Blvd to Wildwood Pkwy.

Consultant to prepare transportation and median design plans including access management. The work will be followed by landscape and irrigation plans.

Approved Budget: \$1,390,034

Expenditures to Date: \$646,146

Completed Tasks:

March

Completion of tree removal and site clearing.*

April

Completion of Irrigation and tree installation.*

Continuing installation of ground cover plantings.

*Sections marked for burrowing owls have not been completed.



Project Lead: Zachary Gogel, Project Manager/CRA

Country Club Blvd Median Landscaping



Palm Tree Blvd Median Landscaping Project

Project Number: C193001012

Estimated Completion Date: Spring 2027

Scope of Work: From the intersection of Palm Tree Blvd and Country Club Blvd to Wildwood Pkwy and Country Club Blvd. Consultant to prepare transportation and median design plans including access management. The work will be followed by landscape and irrigation plans.

Approved Budget: \$3,000,000

Expenditures to Date: \$232,235

Completed Tasks:

March

Lowest bid was unqualified to perform the work.

April

New bid documents were submitted to Procurement to include both Civil and Landscaping.



Project Lead: Zachary Gogel, Project Manager/CRA

Palm Tree Blvd Median Landscaping Project



Cape Coral Pkwy Streetlight Retrofit

Project Number: C193001013

Estimated Completion Date: Summer 2026

Scope of Work: To improve the streetlight reliability by upgrading the electrical infrastructure and replacing the green streetlights along Cape Coral Pkwy from Palm Tree Blvd to Del Prado Blvd.

Approved Budget: \$1,000,000

Expenditures to Date: \$432,488

Completed Tasks:

March

Completed installation of 143 out of 166 light pole. The remaining 23 poles were damaged in shipment and sent back to the manufacture for repair.

April

The 23 repaired poles are expected to arrive by the first week of May. Installation will be completed within two weeks of arrival.



Project Lead: Zachary Gogel, Project Manager/CRA

Bimini Basin Mooring Field - Design and Permitting

Project Number: C703001020

Estimated Completion Date: Winter 2026

Scope of Work: Design and permit a mooring field at the Bimini Basin. Ancillary improvements at Four Freedoms Park include: New seawall (with Captain's walk and connecting sidewalks), dinghy dock, pump out ability, and a modular facility (with public/private restrooms, shower room, laundry/ice machine room, and an office/storage room).

Approved Budget: \$524,899*

Expenditures to Date: \$404,984

*City funded project

Completed Tasks:

March	Received Request for Additional Information from FWC on March 30.
April	Staff responded to FWC Request for Additional Information, including submittal / acceptance of Lee County Manatee Protection Plan Permit.

Project Lead: Chris Camp, Principal Engineer (Public Works - Property Management)

Bimini Basin Mooring Field - Design and Permitting

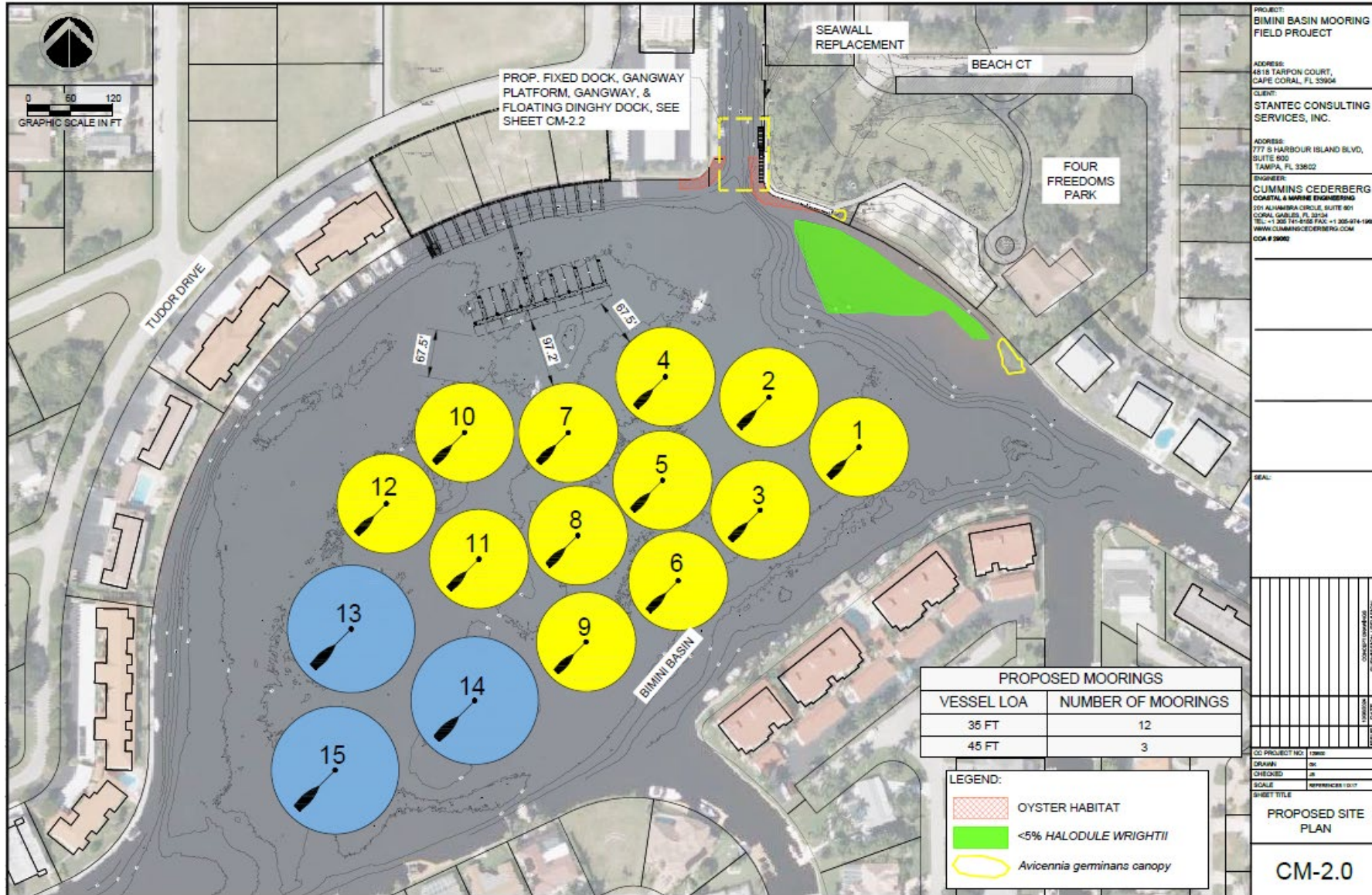

Founders Park – Captains Walk

Project Number: C193001017

Estimated Completion Date: Summer 2026

Scope of Work: Provide waterfront access at Founders Park. 200' x 5' Captains Walk.

Approved Budget: \$98,000

Expenditures to Date: \$0

Completed Tasks:

March

Request for Quote responses received on 3/31/26.

April

After staff review, the lowest responsive bidder was approved at \$77,075. Staff received all documentation to submit for requisition on 4/27/26.



Project Lead: Zachary Gogel, Project Manager/CRA

Founders Park - Captains Walk



Palm Tree Public Square

Project Number: C193001016 **Estimated Completion Date:** Spring 2027 - Design Phase II

Scope of Work: Develop the roughly 1-acre parcel into a new park with landscaping, pedestrian features, and a focal point fountain.

Approved Budget: \$399,630

Expenditures to Date: \$43,361

Completed Tasks:

March

Amendment 1 was approved at the 3/11/26 CRA meeting. This coincided with a budget amendment that was approved by the CRA Board on 3/11/26.

April

City Council approved their budget amendment including the CRA's on 4/15/26. This allowed for the change order to be submitted with procurement to issue the adjusted PO.



Project Lead: Sarah Evins, Special Projects Coordinator/CMO

Palm Tree Public Square

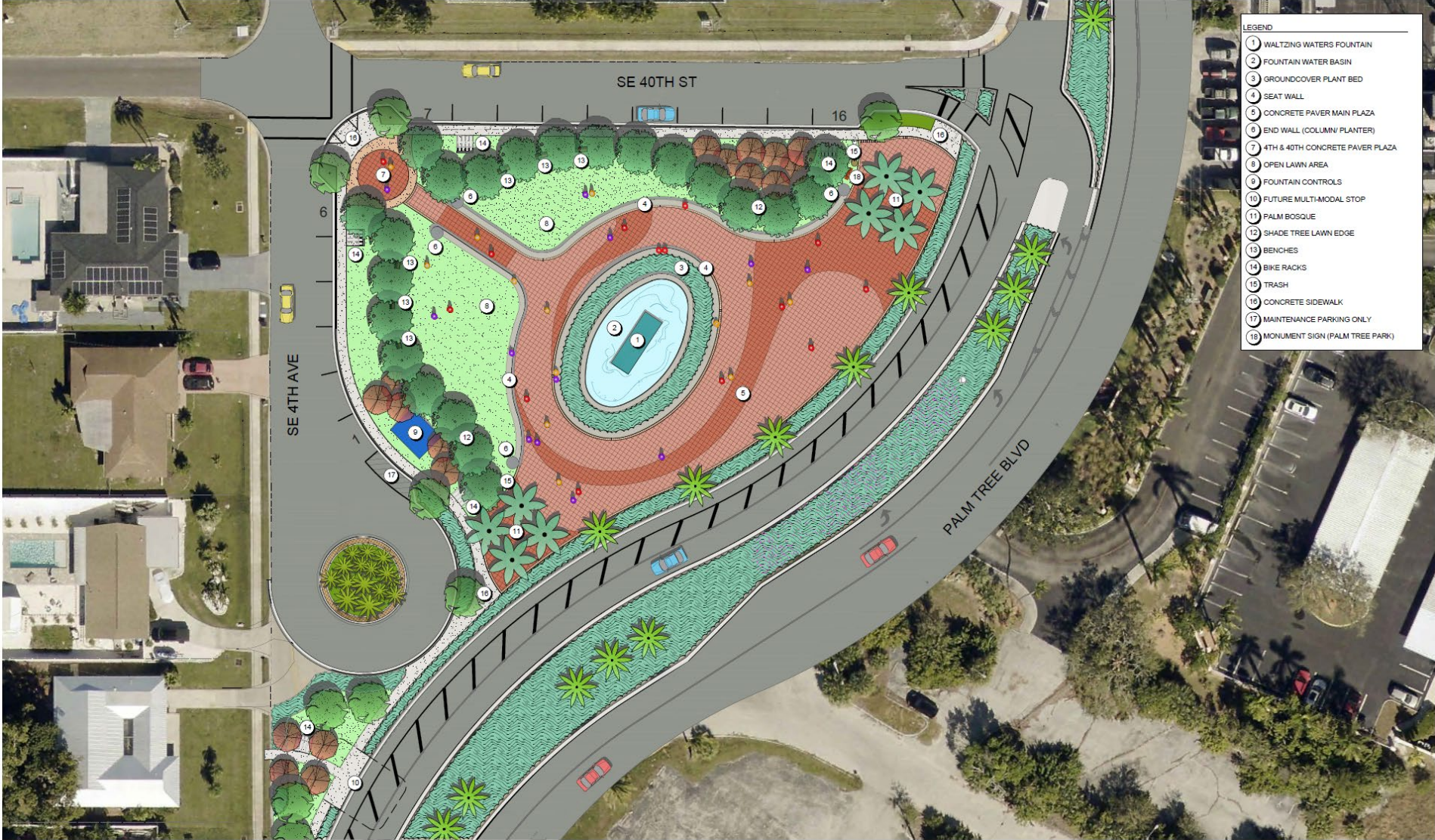

City of Cape Coral
PALM TREE BLVD PARK
 ILLUSTRATIVE SITE PLAN- OPTION 01

Bimini East

Project Number: C190901001

Estimated Completion Date: Summer 2026

Scope of Work: The City of Cape Coral and the South Cape Community Redevelopment Agency (CRA) invite experienced, well-capitalized developers to submit proposals for the redevelopment of approximately 22 acres known as Bimini East. We seek visionary partners to deliver a walkable, vibrant, mixed-use waterfront district that becomes a catalyst for Cape Coral's continued transformation.

Approved Budget: \$45,474,013

Expenditures to Date: \$45,220,929

Current Status:

Negotiations are progressing. The solicitation remains in the cone of silence.

Project Lead: Zachary Gogel, Project Manager/CRA

Bimini East

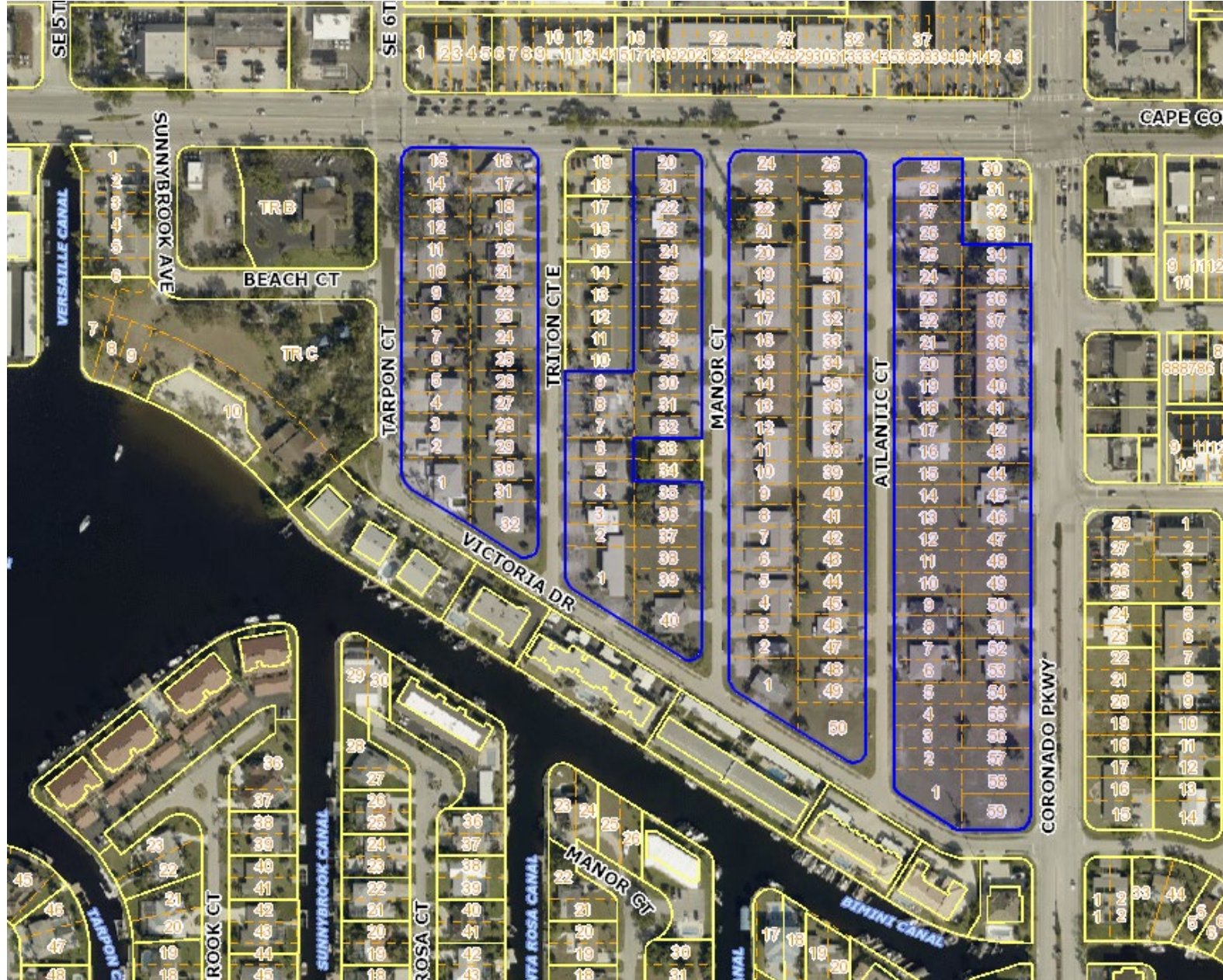

Thank you
Any Questions?

